

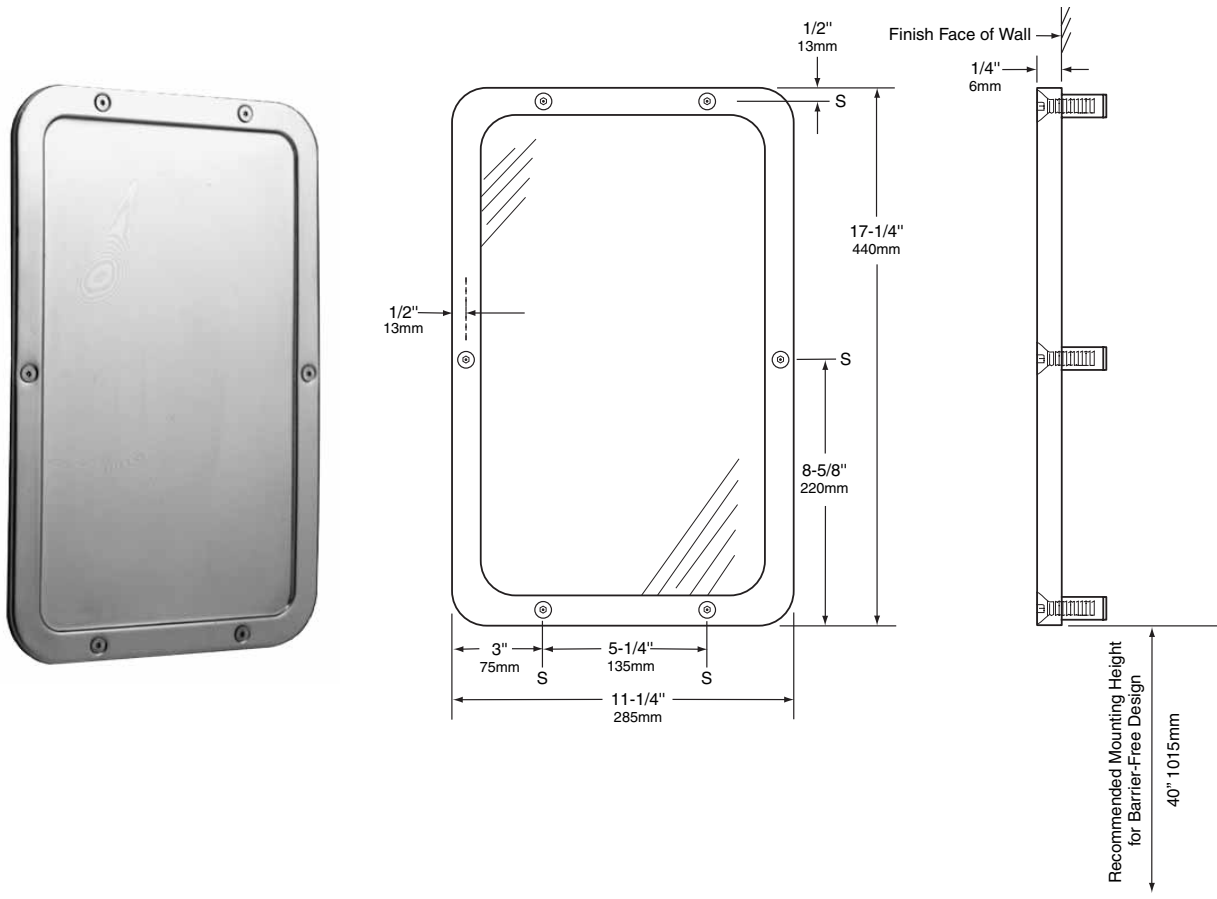

**Technical Data**

# VANDAL-RESISTANT STAINLESS STEEL FRAMELESS MIRROR (SECURED FROM FRONT)

# B-942



**MATERIALS:**

**Mirror & Integral Frame** — Type-430, 18-gauge (1.2mm) stainless steel with bright polished finish. Mirror has 1/4" (6mm) return.

**INSTALLATION:**

Secure unit to wall at all points indicated by an S. Unit has countersunk screw holes and is furnished with six 1/4-20 x 1" (6 x 25mm), tamper-resistant, flat-head, hex-socket, stainless steel machine screws and a security hex key for installation. Expansion shields are not furnished by manufacturer.

**SPECIFICATION:**

Frameless mirror shall be type-430, 18-gauge (1.2mm) stainless steel with bright polished finish. Mirror shall have 1/4" (6mm) return. Mirror shall be protected by fiberboard backing. Mirror shall be furnished with tamper-resistant mounting screws. Manufacturer's service and parts manual shall be provided to the building owner/manager upon completion of project.

**Stainless Steel Frameless Mirror shall be Model B-942 of Bobrick Washroom Equipment, Inc., Clifton Park, New York; Jackson, Tennessee; Los Angeles, California; Bobrick Washroom Equipment Company, Scarborough, Ontario; Bobrick Washroom Equipment Pty. Ltd., Australia; and Bobrick Washroom Equipment Limited, United Kingdom.**