

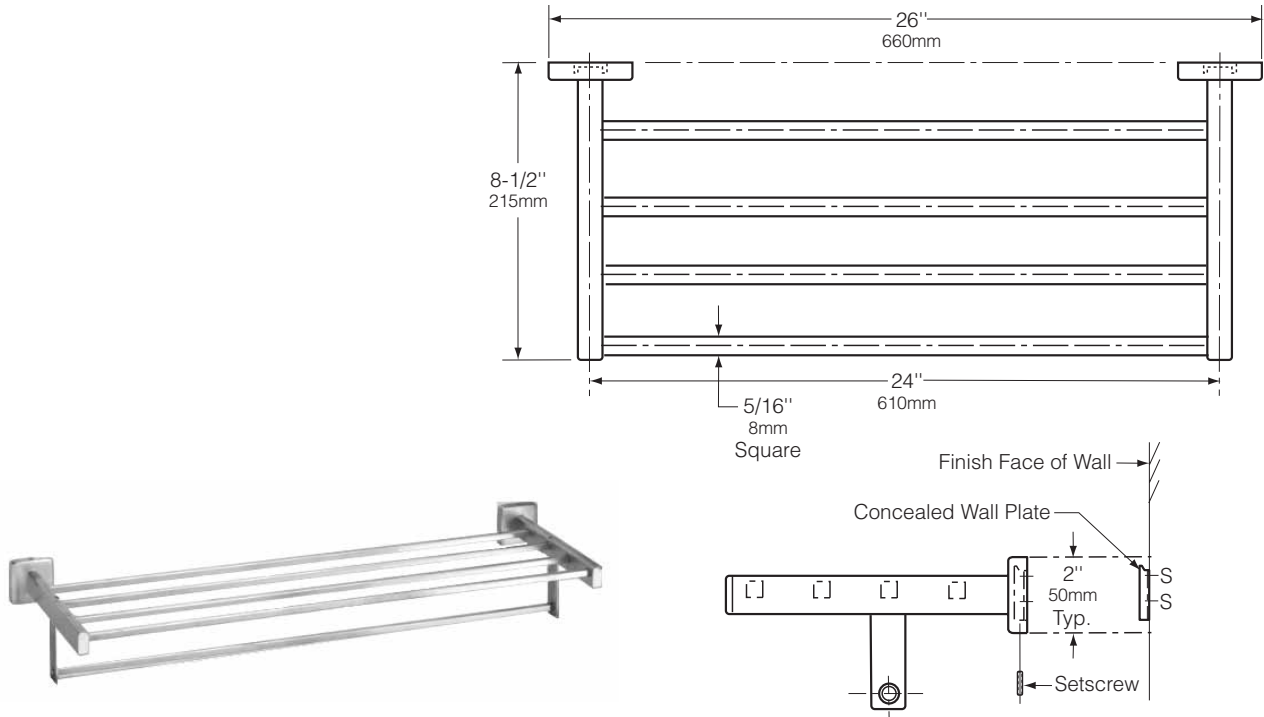

Technical Data

SURFACE-MOUNTED TOWEL SHELF WITH TOWEL BAR

B-676



MATERIALS:

Flanges and Support Arms (2) — 18-8 S, type-304, 22-gauge (0.8mm) stainless steel. Each flange has concealed, 16-gauge (1.6mm) stainless steel mounting bracket. All-welded construction. Secured to wall plates with stainless steel setscrews.

Concealed Wall Plates (2) — 18-8 S, type-304, 16-gauge (1.6mm) stainless steel.

Shelf and Towel Bar — 18-8 S, type-304, heavy-gauge stainless steel. Seamless, 5/16" (8mm) square tubing.

INSTALLATION:

To remove concealed wall plates from back of flanges and mounting brackets, loosen setscrews. Mount each wall plate so prongs are at top; secure with two #8 x 1-1/2" (4.2 x 38mm) sheet-metal screws (not furnished) at points indicated by an S. Engage mounting brackets onto prongs of wall plates, then secure into position by tightening setscrews at bottom of flanges.

Note: Center-to-center of concealed wall plates must be within 1/16" (1.6mm) of the bar length dimension.

For plaster or dry wall construction, provide concealed backing to comply with local building codes, then secure unit with sheet-metal screws (not furnished). For other wall surfaces, provide fiber plugs or expansion shields for use with sheet-metal screws, or provide 1/8" (3mm) toggle bolts or expansion bolts.

SPECIFICATION:

Surface-mounted towel shelf with towel bar shall be type-304 stainless steel with bright polished finish. Flanges and support arms shall be 22 gauge (0.8mm) and equipped with concealed, 16-gauge (1.6mm) mounting brackets that are secured to concealed, 16-gauge (1.6mm) wall plates with stainless steel setscrews. Shelf and towel bar shall be seamless, 5/16" (8mm) square tubing. Manufacturer's service and parts manual shall be provided to the building owner/manager upon completion of project.

Surface-Mounted Towel Shelf With Towel Bar shall be Model 676 of Bobrick Washroom Equipment, Inc., Clifton Park, New York; Jackson, Tennessee; Los Angeles, California; Bobrick Washroom Equipment Company, Scarborough, Ontario; Bobrick Washroom Equipment Pty. Ltd., Australia; and Bobrick Washroom Equipment Limited, United Kingdom.