



Technical Data

TRIMLINE™ SERIES COUNTERTOP PAPER TOWEL DISPENSER

B-526



Rough Countertop Cutout

12-1/4" (310mm) wide
4-1/2" (115mm) high

3/4" to 1-1/2" (19 to 38mm) mounting thickness
17" (430mm) minimum clearance below mounting surface

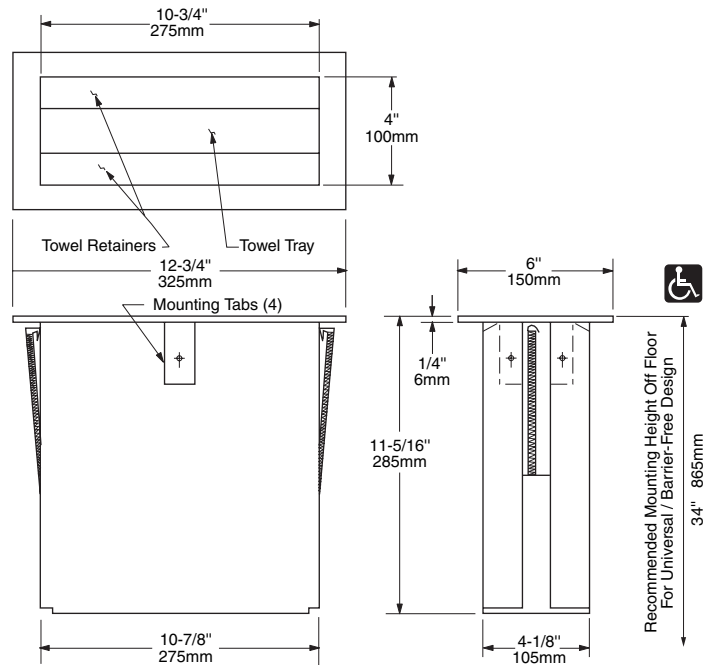

MATERIALS:

Flange — 18-8 S, type-304, 22-gauge (0.8mm) satin finish stainless steel. 1/4" (6mm) 90° return for maximum rigidity.

Paper Towel Dispenser — 18-8 S, type-304, 22-gauge (0.8mm) satin finish stainless steel. All-welded construction. Equipped with two hinged towel retainers and a spring-loaded towel tray. Capacity: 300 C-fold or multifold paper towels.

OPERATION:

Paper towel dispenser accommodates C-fold and multifold paper towels without adjustment or adapters. Patented *push-through* design allows loading from the top by pushing towels downward into dispenser through the two hinged towel retainers.

Designer's Notes: Housing below countertop to conceal paper towel dispenser is not included with unit—must be furnished by others. Paper towel dispenser may be mounted in vertical surfaces of countertop also, including aprons, skirts, or front of cabinets.

INSTALLATION:

Unit is designed for installation in countertop. Mount unit through a cutout specially ordered from countertop manufacturer or field cut. Dimensions of cutout are to be 12-1/4" wide x 4-1/2" high (310 x 115mm). Adjustable mounting tabs accommodate mounting thicknesses from 3/4" to 1-1/2" (19 to 38mm). For complete installation instructions, see Form No. 526-69, packed with each shipment; also available in advance on request.

NOTE: 17" (430mm) minimum clearance below mounting surface is required to allow for full extension of fully loaded towel tray.

SPECIFICATION:

Paper towel dispenser for mounting in countertops shall be type-304 stainless steel with all-welded construction; exposed surfaces shall have satin finish. Flange shall have 1/4" (6mm) 90° return. Paper towel dispenser shall be equipped with two hinged towel retainers and spring-loaded towel tray; capacity shall be 300 C-fold or multifold paper towels. Manufacturer's service and parts manual shall be provided to the building owner/manager upon completion of project.

Countertop-Mounted Paper Towel Dispenser shall be Model B-526 of Bobrick Washroom Equipment, Inc., Clifton Park, New York; Jackson, Tennessee; and Los Angeles, California; Bobrick Washroom Equipment Company, Scarborough, Ontario; Bobrick Washroom Equipment Pty. Ltd., Australia; and Bobrick Washroom Equipment Limited, United Kingdom.