

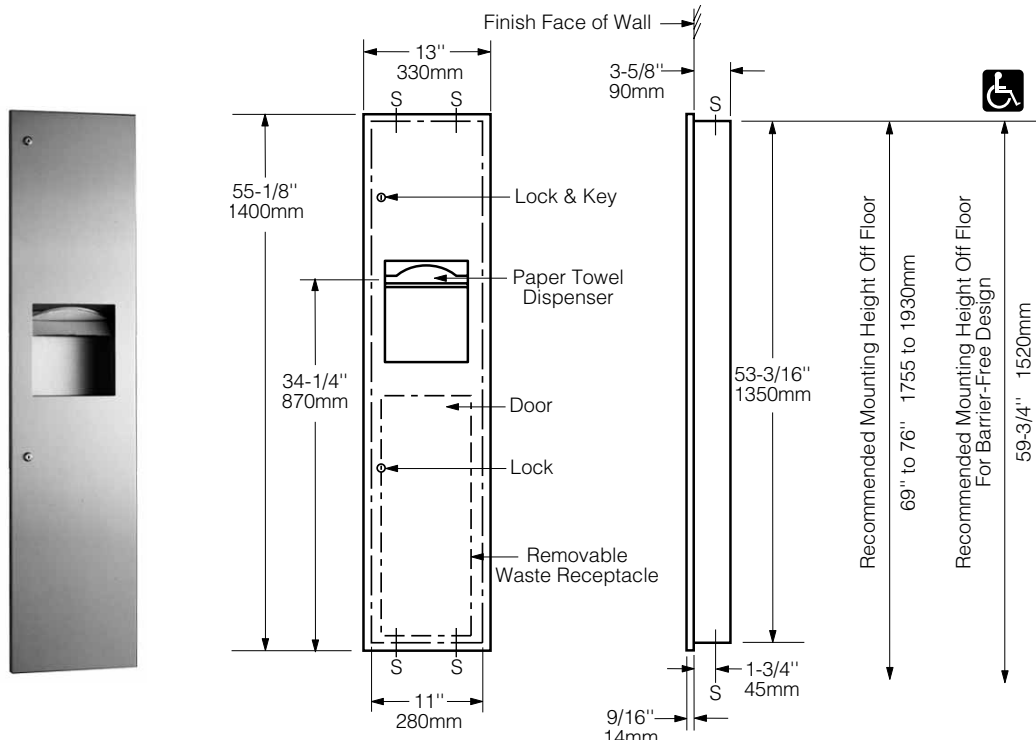

Technical Data

RECESSED PAPER TOWEL DISPENSER AND WASTE RECEPTACLE

B-38034



Rough Wall Opening
11-1/2" (290mm) wide
53-5/8" (1360mm) high
3-3/4" (96mm) minimum recessed depth

MATERIALS:

Cabinet — 18-8 S, type-304, heavy-gauge stainless steel. All-welded construction.

Door — 18-8 S, type-304, 18-gauge (1.2mm) stainless steel with satin finish. 9/16" (14mm) 90° return for maximum rigidity. Secured to cabinet with a concealed, full-length, stainless steel piano-hinge. Equipped with a stainless steel cable door-swing limiter and two tumbler locks keyed like other Bobrick washroom accessories.

Paper Towel Dispenser — 18-8 S, type-304, 22-gauge (0.8mm) stainless steel with satin finish. Rounded towel tray has hemmed opening to dispense paper towel without tearing. Capacity: 600 C-fold or 800 multifold paper towels.

Waste Container — Leak-proof rigid molded plastic. Removable for servicing. Capacity: 3.8 gal. (14.4 L).

OPERATION:

Paper towel dispenser is adjustable to dispense C-fold or multifold paper towels without use of additional adapters or towel trays. To service waste receptacle, unlock door with key provided and remove waste container. Cable door-swing limiter prevents damage to washroom accessories and walls.

INSTALLATION:

Provide framed rough wall opening 11-1/2" wide x 53-5/8" high (290 x 1360mm). Minimum recessed depth required from finish face of wall is 3-3/4" (96mm). Allow clearance for construction features that may protrude into rough wall opening from opposite wall. Coordinate with mechanical engineer to avoid pipes, vents, and conduits. If unit projects above top of wainscot, provide aluminum channel or other filler to eliminate gap between flange and finish face of wall. Mount cabinet with shims between framing and cabinet at all points indicated by an S, then secure unit with #8 x 1-1/4" (4.2 x 32mm) sheet-metal screws (not furnished).

SPECIFICATION:

Recessed paper towel dispenser and waste receptacle shall be type-304 stainless steel with all-welded construction; exposed surfaces shall be satin finish. Door shall be 18 gauge (1.2mm); have 9/16" (14mm) 90° return edges; be secured to cabinet with a concealed, full-length stainless steel piano-hinge; and equipped with a stainless steel cable door-swing limiter and two tumbler locks keyed like other Bobrick washroom accessories. Paper towel dispenser shall be capable of dispensing 600 C-fold or 800 multifold paper towels. Waste receptacle shall be furnished with a removable, leak-proof, rigid molded plastic waste-container with a capacity of 3.8 gal. (14.4 L). Manufacturer's service and parts manual shall be provided to the building owner/manager upon completion of project.

Recessed Paper Towel Dispenser and Waste Receptacle shall be Model B-38034 of Bobrick Washroom Equipment, Inc., Clifton Park, New York; Jackson, Tennessee; Los Angeles, California; Bobrick Washroom Equipment Company, Scarborough, Ontario; Bobrick Washroom Equipment Pty. Ltd., Australia; and Bobrick Washroom Equipment Limited, United Kingdom.