

WALL MOUNTED DRINKING FOUNTAINS



Materials

Wall Mounted Drinking Fountains are manufactured from heavy-gauge, type 304 stainless steel with all exposed surfaces in satin finish. Units incorporate integral splashback for hygiene & ease of cleaning. Smooth radiused design eliminates sharp corners, which can cause injury.

A8900 – accessible pipework where security/aesthetics is not critical

A8901 – fully concealed pipework & fixings

Outlet: Integral perforated drain. Furnished with 40mm BSP waste outlet.

Bubbler: Supplied with chrome plated, shielded bubbler with self-closing push button valve. Valve includes flow adjuster and strainer. Water inlet connection is 10mm compression fitting.

Installation

Ensure wall construction is suitable to support the unit. Mount unit to wall with S-clip provided. Fixings screws not furnished.

Adult Height - Fountain rim is typically mounted 915mm above FFL.

Junior Height - Fountain rim is typically mounted 760mm above FFL.

Refer disabled code for mounting requirements where basin is for disabled use. Adjust height to suit application if required. Do not rough in without certified dimensions.

Important: Installation instructions and current rough-in details should be furnished with each fixture. Do not rough in without certified dimensions. Dimensions are subject to manufacturer's tolerance of +/-10mm.

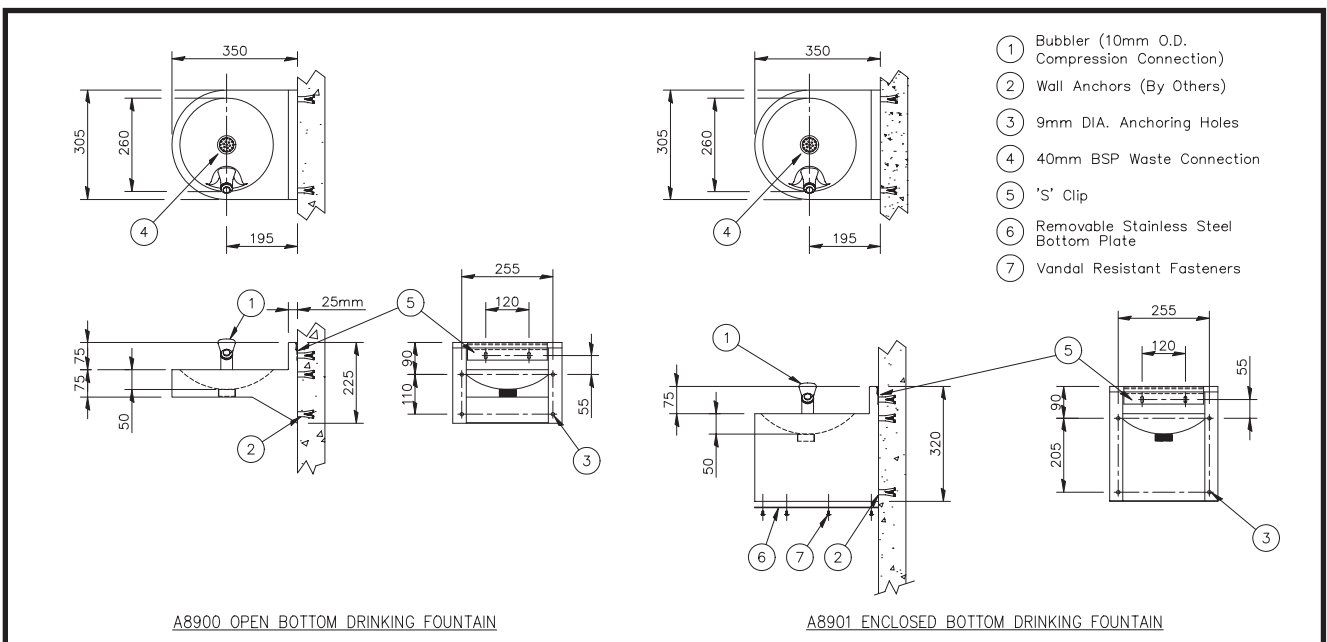

As improvements in the design and performance of RBA products are continuous, specifications may be subject to change without notice.